

# 746 ER

for sliding gates with max weight of 600 kg

746 ER Z16 for rack applications

746 ER Z20 for rack applications (400 Kg)

746 ER CAT for chain applications

746 ER RF for chain applications with idle transmission



## ■ Ideal for residential applications

The control board inside the gearmotor facilitates and speeds up installation, at lower cost. Its compact size makes it ideal for residential applications with gates weighing up to 600 kg.

## ■ Totally safe, reliable in all conditions

Safety is guaranteed by the special, adjustable, oil-bath lubricated anti crushing clutch, and by an intelligent electronic device which, when it detects the presence of an obstacle, reverses and stops gate movement. The FAAC 746 gearmotor performs uniformly, and all commands are supplied by an extremely safe and reliable microprocessor.

## ■ Long life

Constant, complete oil-bath lubrication of mechanical components plus assembly in a high resistance pressure-cast aluminium body ensure a very long life.

## ■ Irreversible

As the gearmotor is non reversing, no electric locks need be installed and, in the event of power failure, the release device (protected by a customized key) makes it possible to open and close the gate manually.



■ Cover



■ Release device with customised key

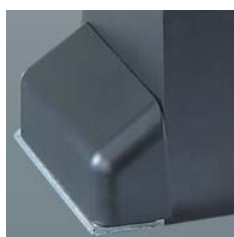

■ Screw cover



■ Base in pressure-cast aluminium with cathoporesis treatment



- 1 780D control board
- 2 Protection cover
- 3 Inductive limit-switch (chain version)

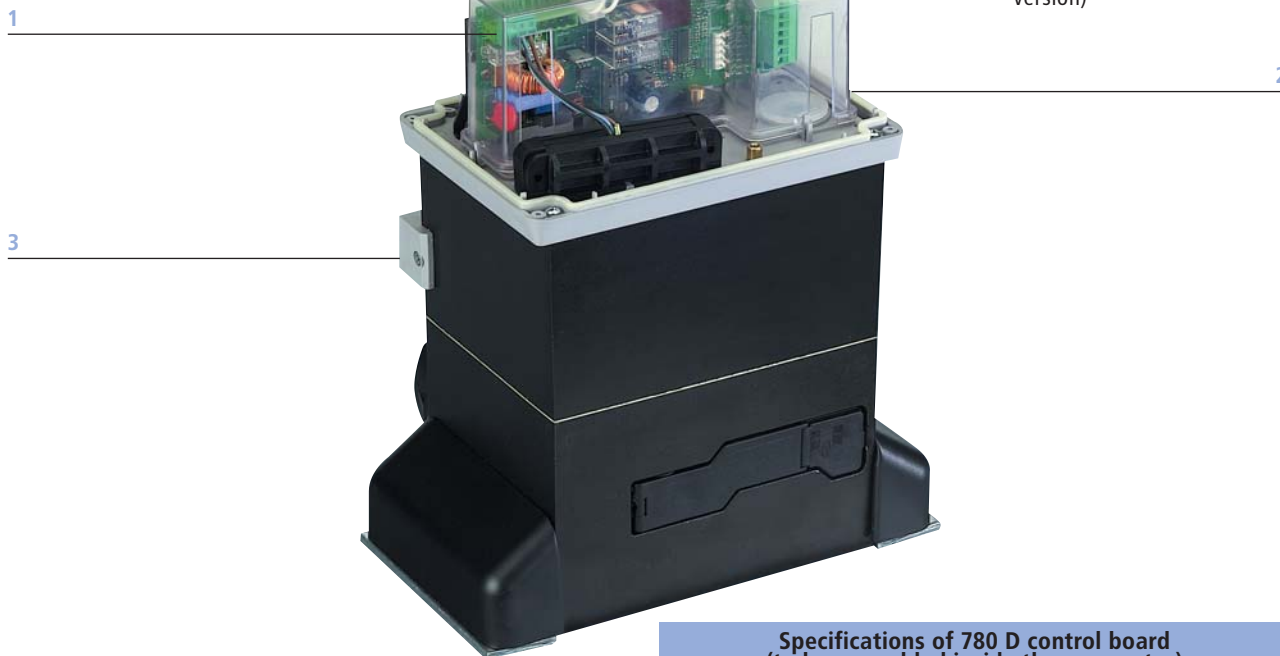

#### DIMENSIONS

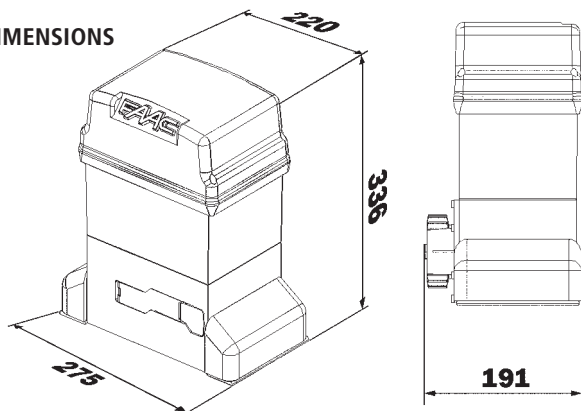

Values in mm

#### Specifications of 780 D control board (to be assembled inside the gearmotor)

Power supply	230 Vac (+6%-10%) 50 Hz
Absorbed power	10 W
Motor max. load	1000 W
Accessories max. load	0,5 A
Operating ambient temperature	-20°C ÷ +55°C
Fuses	2
Function logics	Automatic/"Stepped" automatic/Semi-automatic/Safety devices/Semi-automatic B/Dead-man C/"Stepped" semi-automatic/Mixed B/C logic
Work time	Programmable (from 0 to 4,1 min)
Pause time	Programmable (from 0 to 4,1 min)
Thrust force	Adjustable over 50 levels
Terminal board inputs	Open - Partially Open - Opening safety devices - Closing safety devices - Stop - Edge - Power supply+earth
On-connector inputs	Opening and closing limit-switch/Motor capacitor
Terminal board outputs	Flashing lamp - Motor - 24Vdc accessories power supply - 24Vdc indicator-light - Timed output - Electric lock command - "Traffic lights" - Fail safe
Rapid connector	5-pin card connection for Minidéc - Decoder or RP receivers
Programming	Nr. 3 keys(+,-,F) and display, "basic" or "advanced" mode
"Basic" mode programmable functions	Function logic - Pause time - Thrust force - Opening-closing direction
"Advanced" mode programmable functions	Torque at initial thrust - Braking - Fail safe - Pre-flashing - Indicator-light/Timed output/Electric lock or "traffic lights" command- Opening and closing safety devices logic - Encoder/Anti-crushing sensitivity - Deceleration - Partial opening time - Worktime
Status indication	Display

Technical specifications 746 ER	Z16	Z20	CAT	RF
Power supply	230 Vac (+ 6%-10%) 50 (60) Hz			
Electric motor	Single-phase, bi-directional			
Absorbed power	300 W			
Absorbed current	1.5 A			
Traction and thrust force	0÷62 daN	0÷50 daN		
Motor rotation speed	1.400 rpm			
Thermal protection on motor winding	120 °C			
Clutch	Twin-disk in oil bath			
Reduction ratio	1:30			
Operating ambient temperature	-20 °C ÷ + 55°C			
Weight with oil	14 Kg			
Type of oil	FAAC OIL XD 220			
Gate speed	9.6 m/min.	12 m/min.		
Protection class	IP 44			

Model	Use		Control board
	Max weight (kg)	Use frequency (cycles/hour)	
746 ER Z16	600	70	780 D included
746 ER Z20	400	70	780 D included
746 ER CAT (*)	-	70	780 D included
746 ER RF (*)	-	70	780 D included